

CROWN

Specifications

WR Series

Heavy Duty Pedestrian
Reach Stacker

WR

Series



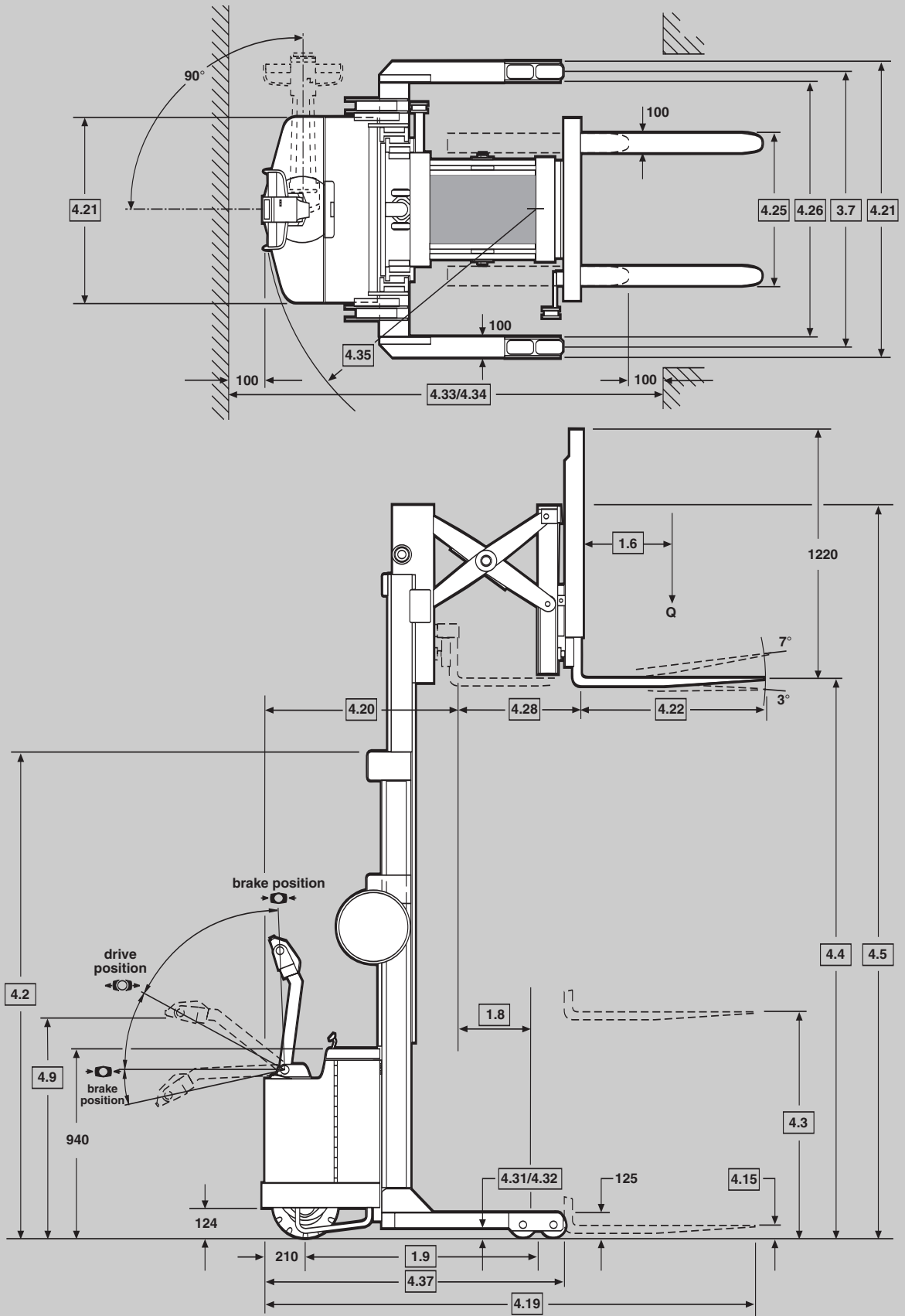

WR Series

Specifications

General Information	1.1	Manufacturer	Crown Equipment Corporation					
	1.2	Model			WRTL	WRTF	WRTT	
	1.3	Prime Mover			electric	electric	electric	
	1.4	Operator Type			walkie	walkie	walkie	
	1.5	Load Capacity		Q t	0.9	0.9	0.9	
	1.6	Load Centre		c mm	600	600	600	
	1.8	Load Distance	w. tilt / w. o. tilt	x mm	395 / 452	395 / 452	422 / 480	
	1.9	Wheel Base		y mm	1168*	1168*	1250*	
	2.1	Weight	less battery		kg	1345, 1395, 1480	1380, 1430, 1510	1640
Tyres	3.1	Tyre Type			rubber/polyurethane	rubber/polyurethane	rubber/polyurethane	
	3.2	Wheel Size	front		mm	Ø 340 x 140	Ø 340 x 140	Ø 340 x 140
	3.3	Wheel Size	rear		mm	Ø 125 x 70	Ø 125 x 70	Ø 125 x 70
	3.5	Wheels	number (x = driven) front/rear			1 x / 4	1 x / 4	1 x / 4
	3.6	Track Width	front	b10	mm	drive unit central	drive unit central	drive unit central
	3.7	Track Width	rear	b11	mm	965 – 1365	965 – 1365	965 – 1365
	Dimensions	4.1	Forkcarriage Tilt	forwards / backwards	°	angle	3 / 7	3 / 7
4.2		Mast	collapsed height	h1	mm	1805, 2110, 2415	1805, 2110, 2415	1805
4.3		Free Lift	w.o. load backrest	h2	mm	305	915**, 1220**, 1525**	915**
4.4		Lift Height		h3	mm	2590, 3200, 3810	2590, 3200, 3810	3860
4.5		Mast	extended height, w.o. load backr.**	h4	mm	3495, 4105, 4715	3495, 4105, 4715	4765
4.9		Tiller Arm Height	in drive position min. / max.	h14	mm	825 / 1120	825 / 1120	825 / 1120
4.10		Outrigger Height		h8	mm	125	125	125
4.15		Lowered Fork Height		h13	mm	64	64	64
4.19		Overall Length***	fork length 1100 mm w.tilt/w.o.tilt*	l1	mm	2085 / 2025	2085 / 2025	2140 / 2140
4.20		Headlength	w. tilt / w.o. tilt*	l2	mm	985 / 925	985 / 925	1040 / 985
4.21		Overall Width	front / rear	b1/b2	mm	915 / 1065 – 1465		
4.22		Fork Dimensions		thxwxl	mm	40 x 100 x 800, 1000, 1100, 1220		
4.23		Fork Carriage	ISO class			2A	2A	2A
4.24		Fork Carriage Width	incl. load backrest	b3	mm	910 – 1070 and 1220		
4.25		Width Across Forks		b5	mm	200 – 800 in 75 mm increments		
4.26		Inside Straddle		b4	mm	865 – 1265 in 50 mm increments		
4.28		Reach		l4	mm	610	610	610
4.31		Ground Clearance	with load below mast	m1	mm	75	75	75
4.32		Ground Clearance	centre wheelbase	m2	mm	50	50	50
4.33		Working Aisle Width	1000x1200 traverse w.tilt/w.o.tilt*	Ast	mm	2440 / 2400	2440 / 2400	2500 / 2460
4.34	Working Aisle Width	800x1200 length w. tilt / w.o. tilt*	Ast	mm	2540 / 2430	2540 / 2430	2540 / 2490	
4.35	Turning Radius		Wa	mm	1380*	1380*	1465*	
4.37	Length	over Outrigger	l7	mm	1520*	1520*	1605*	
Performance	5.1	Travel Speed	w. / w.o. load		km/h	4.3 / 5.1	4.3 / 5.1	4.3 / 5.1
	5.2	Lift Speed	w. / w.o. load		m/s	0.18 / 0.28	0.13 / 0.28	0.15 / 0.28
	5.3	Lower Speed	w. / w.o. load		m/s	0.17 / 0,14	0.13 / 0,14	0.16 / 0.14
	5.4	Reach Speed	w. / w.o. load		m/s	0.2 / 0.2	0.2 / 0.2	0.2 / 0.2
	5.7	Max. Gradeability	w. load		%	10	10	10
	5.10	Service Brake				mechanic	mechanic	mechanic
Motors	6.1	Traction Motor	60 min rating		kW	1.0	1.0	1.0
	6.2	Lift Motor	15% on time		kW	3.3	3.3	3.3
	6.3	Max. Battery Box Size	opt. 1 / opt. 2	lxwxh	mm	168 x 890 x 590 / 333 x 806 x 590		
	6.4	Battery Voltage	nominal capacity 5h opt.1/opt.2		V/Ah	24/225 • 24/525	24/225 • 24/525	24/225 • 24/525
	6.5	Battery Weight	min. / max. opt. 1 / opt. 2		kg	230/320•440/635	230/320•440/635	230/320•440/635
Misc.	8.1	Type of Controller				resistor	resistor	resistor
	8.2	Available Working Pressure for Attachments			bar	127	127	127
	8.3	Available Oilflow for Attachments			l/min.	11.7	11.7	11.7

* Add 165 mm if Battery option 2 is used

** Subtract 330 mm from free lift of WRTF and WRTT models, and add 330 mm to extended height of all models if load backrest is required

*** without reach

WR Series

Specifications

General Information	1.1	Manufacturer	Crown Equipment Corporation					
	1.2	Model			WRTL	WRTF	WRTT	
	1.3	Prime Mover			electric	electric	electric	
	1.4	Operator Type			walkie	walkie	walkie	
	1.5	Load Capacity		Q	t	1.35	1.35	1.35
	1.6	Load Centre		c	mm	600	600	600
	1.8	Load Distance	w. tilt, w.o. tilt	x	mm	395 / 452	395 / 452	422 / 480
	1.9	Wheel Base		y	mm	1333	1333	1415
	2.1	Weight	less battery		kg	1345, 1395, 1480	1380, 1430, 1510	1640
Tyres	3.1	Tyre Type			rubber/polyurethane	rubber/polyurethane	rubber/polyurethane	
	3.2	Wheel Size	front		mm	Ø 340 x 140	Ø 340 x 140	Ø 340 x 140
	3.3	Wheel Size	rear		mm	Ø 125 x 70	Ø 125 x 70	Ø 125 x 70
	3.5	Wheels	number (x = driven) front / rear			1 x / 4	1 x / 4	1 x / 4
	3.6	Track Width	front	b10	mm	drive unit central	drive unit central	drive unit central
	3.7	Track Width	rear	b11	mm	965 – 1365	965 – 1365	965 – 1365
	Dimensions	4.1	Forkcarriage Tilt	forwards/backwards	°	angle	3 / 7	3 / 7
4.2		Mast	collapsed height	h1	mm	1805, 2110, 2415	1805, 2110, 2415	1805
4.3		Free Lift	w.o. load backrest	h2	mm	305	915**, 1220**, 1525**	915**
4.4		Lift Height		h3	mm	2590, 3200, 3810	2590, 3200, 3810	3860
4.5		Mast	extended height, w.o. load backr.**	h4	mm	3495, 4105, 4715	3495, 4105, 4715	4765
4.9		Tiller Arm Height	in drive position min. / max.	h14	mm	825 / 1120	825 / 1120	825 / 1120
4.10		Outrigger Height		h8	mm	125	125	125
4.15		Lowered Fork Height		h13	mm	64	64	64
4.19		Overall Length***	fork length 1100mm w.tilt/w.o.tilt*	l1	mm	2250 / 2190	2250 / 2190	2305/2305
4.20		Headlength	w. tilt / w.o. tilt*	l2	mm	1150 / 1090	1150 / 1090	1205 / 1150
4.21		Overall Width	front / rear	b1/b2	mm	915 / 1065 - 1465		
4.22		Fork Dimensions		thxwxl	mm	40 x 100 x 800, 1000, 1100, 1220		
4.23		Fork Carriage	ISO class			2A	2A	2A
4.24		Fork Carriage Width	incl. load backrest	b3	mm	910 - 1070 and 1220		
4.25		Width Across Forks		b5	mm	200 – 800 in 75 mm increments		
4.26		Inside Straddle		b4	mm	865 – 1265 in 50 mm increments		
4.28		Reach		l4	mm	610	610	610
4.31		Ground Clearance	with load below mast	m1	mm	75	75	75
4.32		Ground Clearance	centre wheelbase	m2	mm	50	50	50
4.33		Working Aisle Width	1000x1200 traverse w.tilt/w.o.tilt*	Ast	mm	2600 / 2570	2600 / 2570	2670 / 2630
4.34	Working Aisle Width	800 x 1200 length w.tilt / w.o.tilt*	Ast	mm	2700 / 2600	2700 / 2600	2700 / 2660	
4.35	Turning Radius		Wa	mm	1545	1545	1630	
4.37	Length	over Outrigger	l7	mm	1685	1685	1770	
Performance	5.1	Travel Speed	w. / w.o. load		km/h	4.3 / 5.1	4.3 / 5.1	4.3 / 5.1
	5.2	Lift Speed	w. / w.o. load		m/s	0.13 / 0,21	0.14 / 0.21	0.15 / 0.21
	5.3	Lower Speed	w. / w.o. load		m/s	0.15 / 0.14	0.14 / 0.14	0.17 / 0.14
	5.4	Reach Speed	w. / w.o. load		m/s	0.2 / 0.2	0.2 / 0.2	0.2 / 0.2
	5.7	Max. Gradeability	w. load		%	10	10	10
	5.10	Service Brake				mechanic	mechanic	mechanic
Motors	6.1	Traction Motor	60 min rating		kW	1.0	1.0	1.0
	6.2	Lift Motor	15% on time		kW	3.3	3.3	3.3
	6.3	Max. Battery Box Size		lxwxh	mm	333 x 806 x 590	333 x 806 x 590	333 x 806 x 590
	6.4	Battery Voltage	nominal capacity 5h		V/Ah	24 / 600	24 / 600	24 / 600
	6.5	Battery Weight	min. / max.		kg	440 / 635	440 / 635	440 / 635
Misc.	8.1	Type of Controller				resistor	resistor	resistor
	8.2	Available Working Pressure for Attachments			bar	127	127	127
	8.3	Available Oilflow for Attachments			l/min.	11.7	11.7	11.7

* Add 165 mm if Battery option 2 is used

** Subtract 330 mm from free lift of WRTF and WRTT models, and add 330 mm to extended height of all models if load backrest is required

*** without reach

Standard Equipment

1. Three speeds forward and reverse.
2. Battery compartment rollers.
3. Emergency power disconnect.
4. Key switch.
5. Horn.
6. Safety shield.
7. Polyurethane drive tyre.
8. Polyurethane load wheels.
9. Third-speed cutoff switch.
10. SBE battery connector.
11. Reversing button.
12. Load backrest.
13. Carriage tilt.

Optional Equipment

1. SCR speed control.
2. Rubber drive tyre
Ø 340 x 140 mm.
3. Battery discharge indicator.
4. Battery discharge indicator with lift lockout.
5. Hour metre.
6. Raise and lower buttons in control handle.
7. Optional lift heights.
8. Corrosion conditioning.
9. Freezer conditioning.
10. Special paint.
11. Power steering.

Electrical System

Standard equipment includes:

1. 24 volt electrical system.
2. Series wound high torque 1.0 kW drive motor.
3. Series wound high torque 3.3 kW lift motor.
4. Heavy duty pump contactor with replaceable tips.
5. Four heavy duty travel speed contactors. A solid-state time relay provides controlled acceleration between 2nd and 3rd speed.
6. Fused control and power circuits.
7. Colour coded wiring for ease of service.
8. Key switch.
9. Power disconnect lever.

Hydraulic System

Standard equipment includes:

1. Heavy duty motor and gear pump assembled as an integral unit. Pump and motor unit hinged for easy accessibility to electrical system.
2. Spool-type hydraulic control valve with built-in check and relief valve.
3. Pressure compensating flow control valve at base of lift cylinder regulates maximum lowering speed.
4. Lift cylinder rams are hard chrome plated for smooth operation and increased life and are equipped with long-life polyurethane packings. Lift cylinders are designed to operate at optimum hydraulic pressure depending on capacity of truck. All WRTF and WRTT models are equipped with three cylinder cluster to provide full free lift.
5. Movable oil reservoir permits easy accessibility to hydraulic system.
6. Overload valve set to prevent lift when system reaches maximum pressure.
7. Centrally located levers for raising, lowering, tilt, and reach are standard equipment. These throttles permit infinite control of fork positioning.

Drive Unit

Gear drive from motor to drive wheel axle. The gear train is mounted on ball and tapered roller bearings, and operates in an oil filled, sealed housing.

Reach Mechanism

Heavily constructed pantograph type reach mechanism extends 610 mm. Dual reach cylinders used on WRTL and WRTF units. Large single cylinder used on all triple telescopic units. Mechanism features: chrome plated cylinder rods, hydraulic cushions at both ends of stroke, lifetime-lubricated sealed channel roller bearings, anti-friction bearings at centre pivots, and self-aligning, grease lubricated spherical bearings.

Tilt

Carriage tilts 7° up and 3° down. Designed to operate in all reach positions and at all lifting heights.

Brake

Internal expanding mechanical brake with Ø 127 mm drum and bonded brake linings. Brake is applied when control handle is within 15° of full vertical or full horizontal position.

Power Unit Structure

Hinged access doors permit easy entry to all electric and hydraulic components. Chassis is equipped with rollers for easy battery installation and removal.

Lift Structure

Outer and inner masts are constructed from hot rolled steel I - beam. Telescoping mast section nests in main upright to provide good visibility for operator.

Control Handle

Control handle has dual twist-grips which control three speeds forward and reverse. Twist-grips return to neutral when released. The handle contains a large safety button which reverses the direction of the truck should the button touch the operator. A large horn button is standard equipment, as is a third speed cut-off switch.

Safety Switches

1. Third speed switch in control handle may be used to shut off high speed when operating in congested areas.
2. Limit switch automatically reduces maximum travel speed immediately upon extension of second and third stages on WRTF and WRTT models, and when forks extend above 1727 mm on WRTL models.
3. Reversing button on control handle reverses direction of travel when actuated by the operator.

Safety Regulations

Conforms to European safety standards. Dimensions and performance data given may vary due to manufacturing tolerances. Performance is based on an average size vehicle and is affected by weight, condition of truck, how it is equipped and the conditions of the operating area. Crown products and specifications are subject to change without notice.

